

advanced FLOW engineering

Cold Air Intake System

Instruction Manual P/N: 56-70065D / 56-70065R

Make: Toyota
Make: Toyota

Model: GR Corolla
Model: GR Yaris

Year: 2023-2024
Year: 2021-2023

Engine: L3-1.6L(t)
Engine: L3-1.6L(t)



- Please read the entire instruction manual before proceeding.
- Ensure all components listed are present.
- If you are missing any of the components, call customer support at 951-493-7185.
- Ensure you have all necessary tools before proceeding.
- Do not attempt to work on your vehicle when the engine is hot.
- Retain factory parts for future use.

Label	Qty.	Description	Part Number
A	1	Air Filter (Pro 5R) For 56-70065R	24-91103
A	1	Air Filter (Pro DRY S) For 56-70065D	21-91103
B	1	Tube	05-5670065B1
C	1	Housing	05-5670065B2
D	2	Clamp, #048 (2-9/16" - 3-1/2 ")	03-50007
E	1	Screw, M5 x 16mm	03-50322
F	1	Cap, Hi-Temp	03-50484
G	2	Screw, M4 x 8mm	03-50491
H	1	Coupling, Silicone Bellow (3-1/4"ID x 2-1/2"L)	05-01416
J	1	Plug, Air Box	05-01527
K	3	Mount, Aluminum, M6	05-01759
L	2	Clip, Hose Holder	05-01761

Installation will require the following tools:

Socket set, Wrench Set, Extension, Ratchet, T-20 Torx Screwdriver, Phillips Screwdriver

Warranty Information available at: <https://afepower.com/contact#warranty>

Emissions Disclaimer: This product is not currently CARB exempt and is not available for purchase in California or for use on any vehicle registered with the California Department of Motor Vehicles.

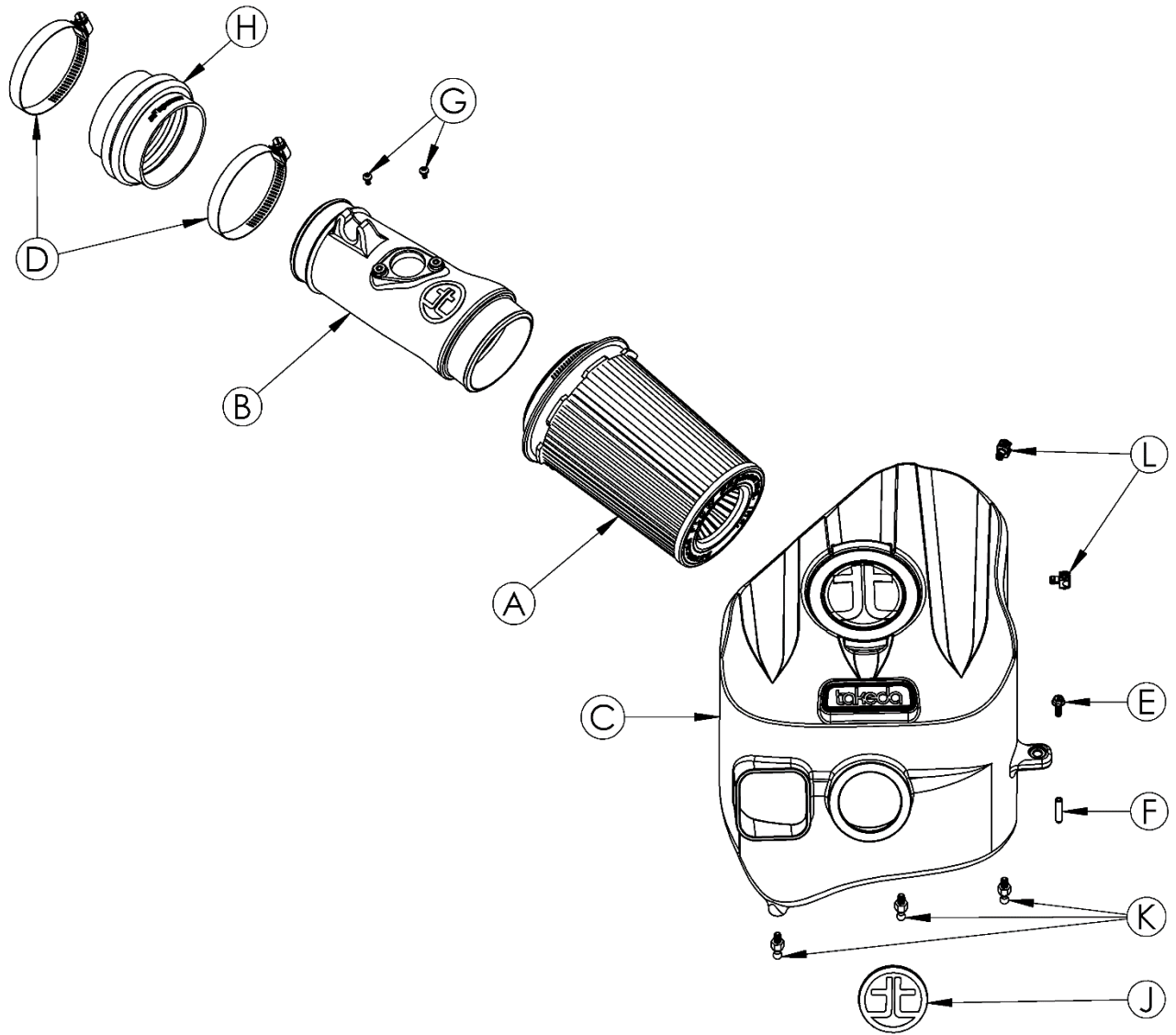

**Figure A****Refer to Figure A for Steps 1-2**

Step 1: Remove engine cover.

Step 2: Remove front cover by carefully removing the seven (7) factory retainer clips.

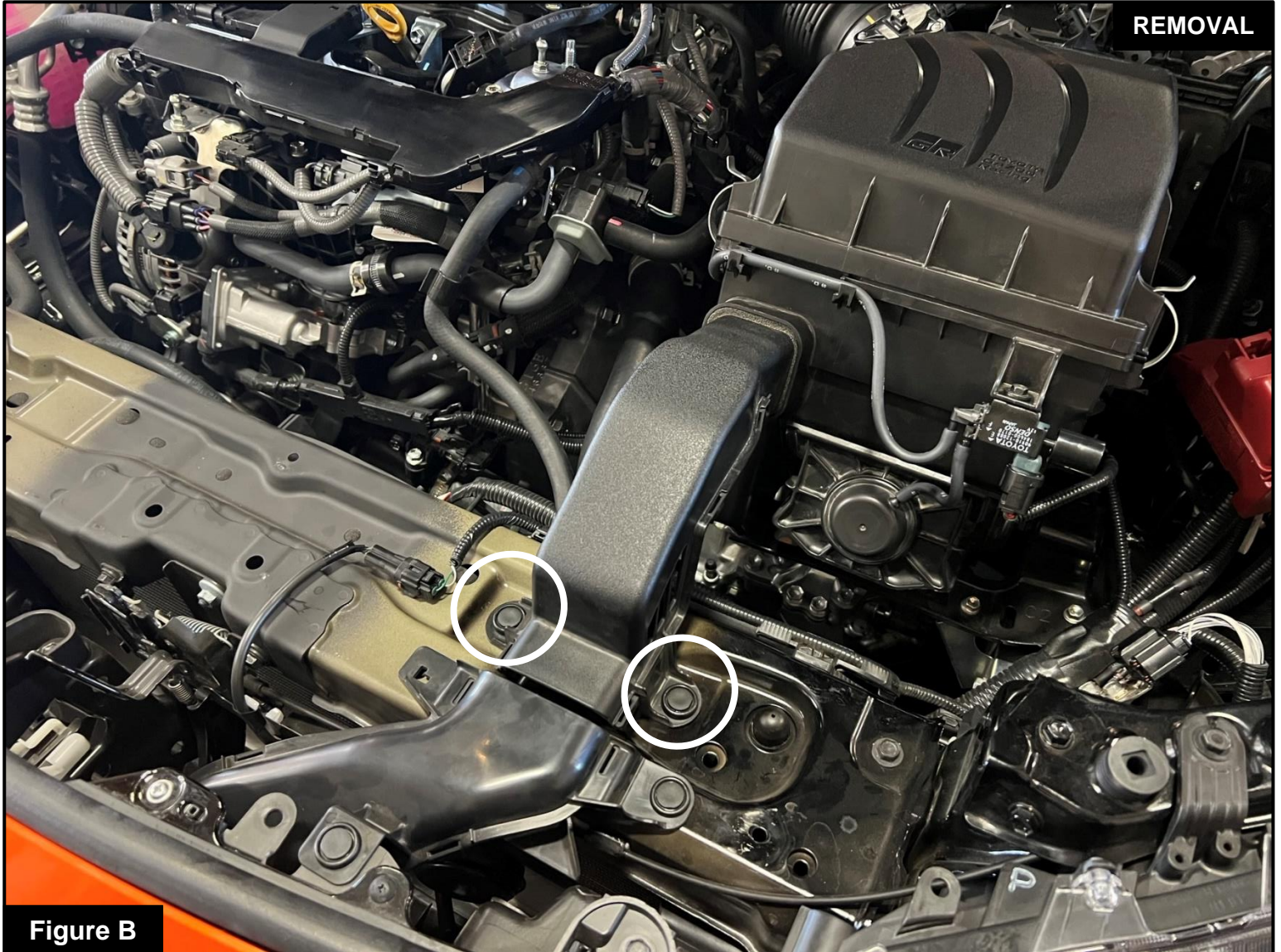

Figure B

Refer to Figure B for Steps 3-4

Step 3: Remove the two (2) factory retainer clips holding down the factory air scoop.

Step 4: Carefully remove the factory scoop from the airbox.

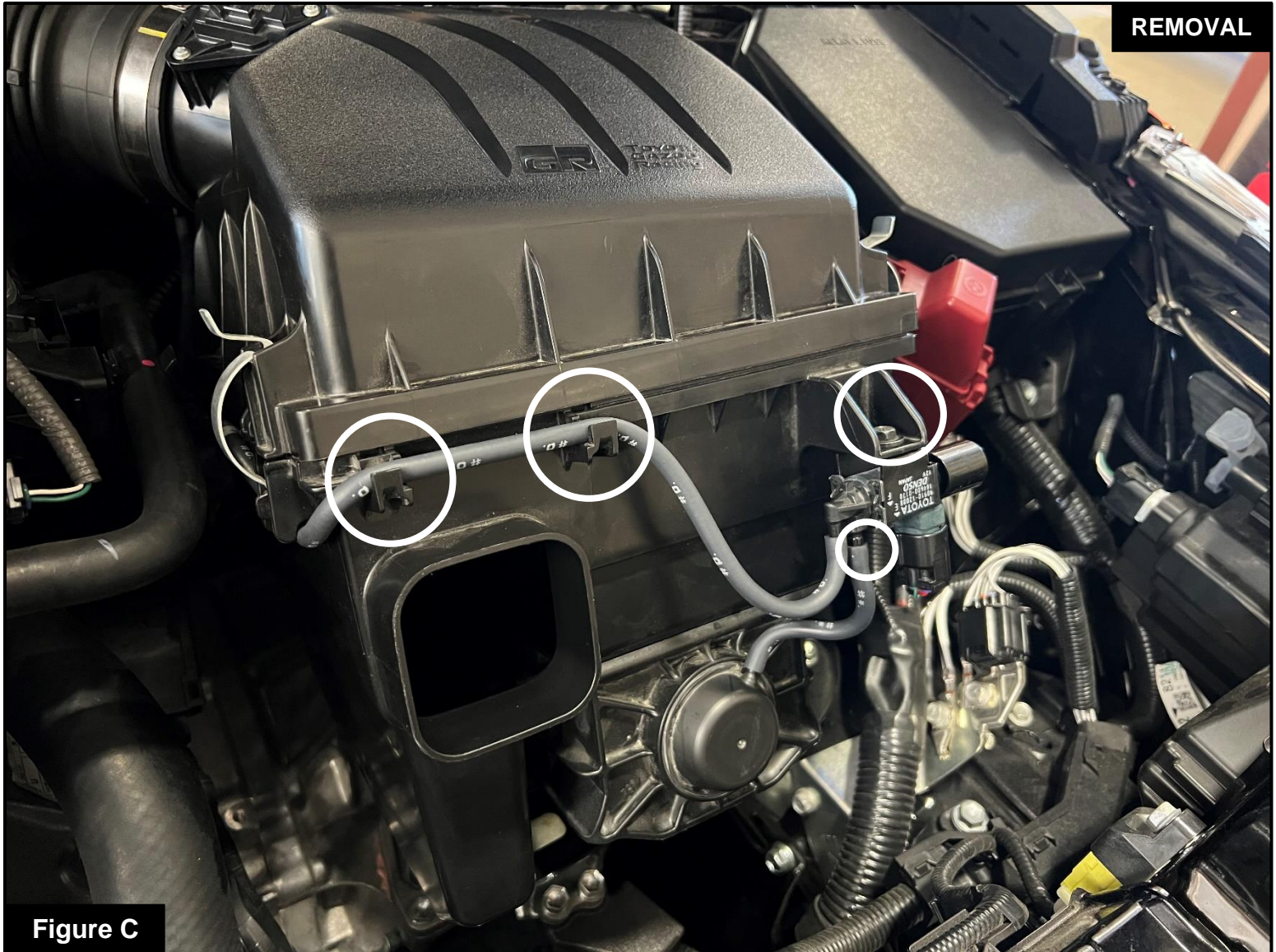

Figure C

Refer to Figure C for Steps 5-7

Step 5: Detach the vacuum hose from the airbox.

Step 6: Detach the small vacuum house from the actuator.

Step 7: Remove the bolt holding down the actuator to the airbox by using an 8mm nut driver.



Refer to Figure D for Step 8

Step 8: Detach harness from airbox.

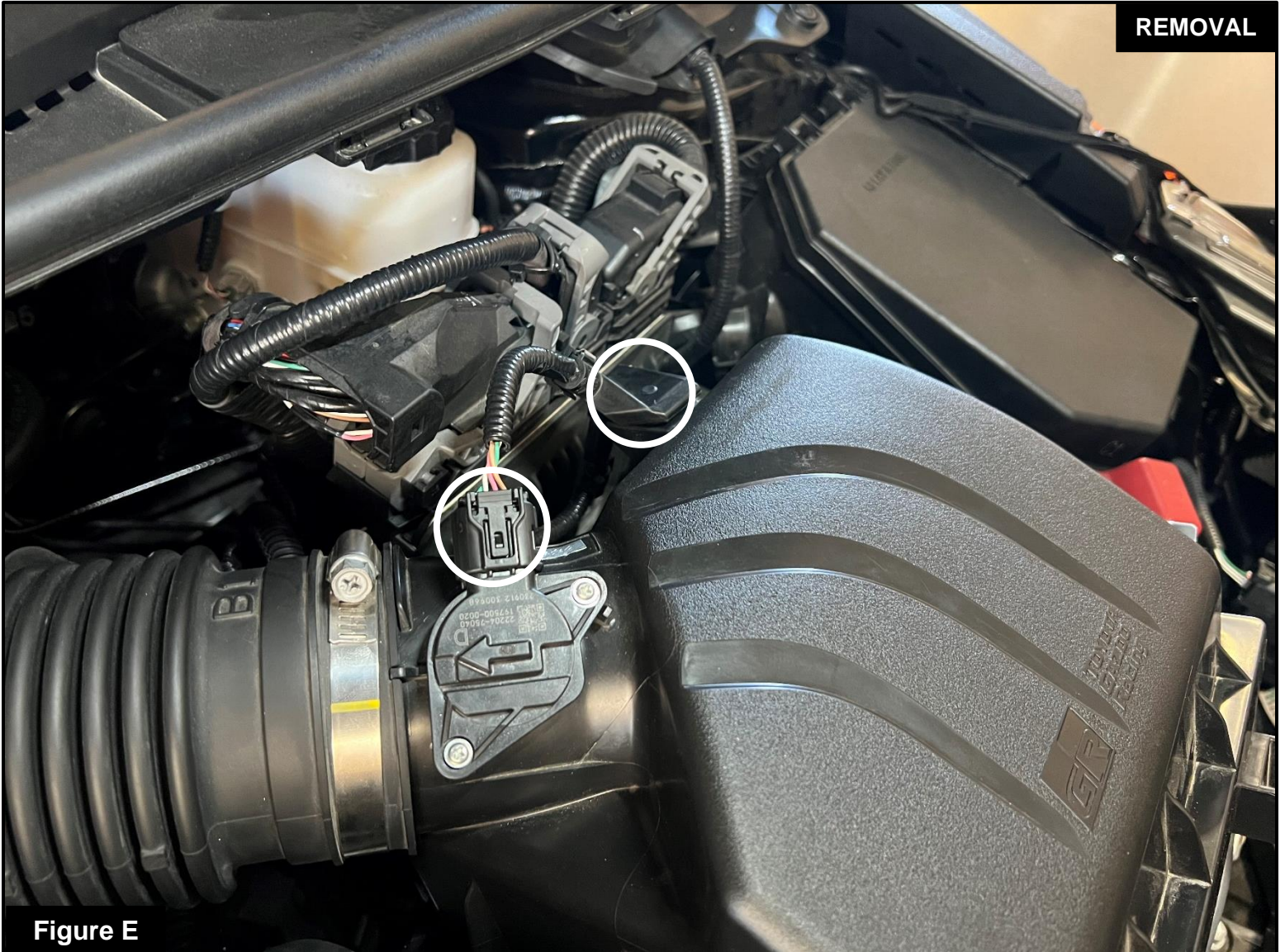

Figure E

Refer to Figure E for Steps 9-10

Step 9: Disconnect the MAF sensor.

Step 10: Detach the MAF sensor harness from the factory airbox.

**Figure F****Refer to Figure F for Steps 11-12**

Step 11: Loosen the clamp on the turbo inlet by using a 10mm nut driver.

Step 12: Detach the hose from the intake tube.

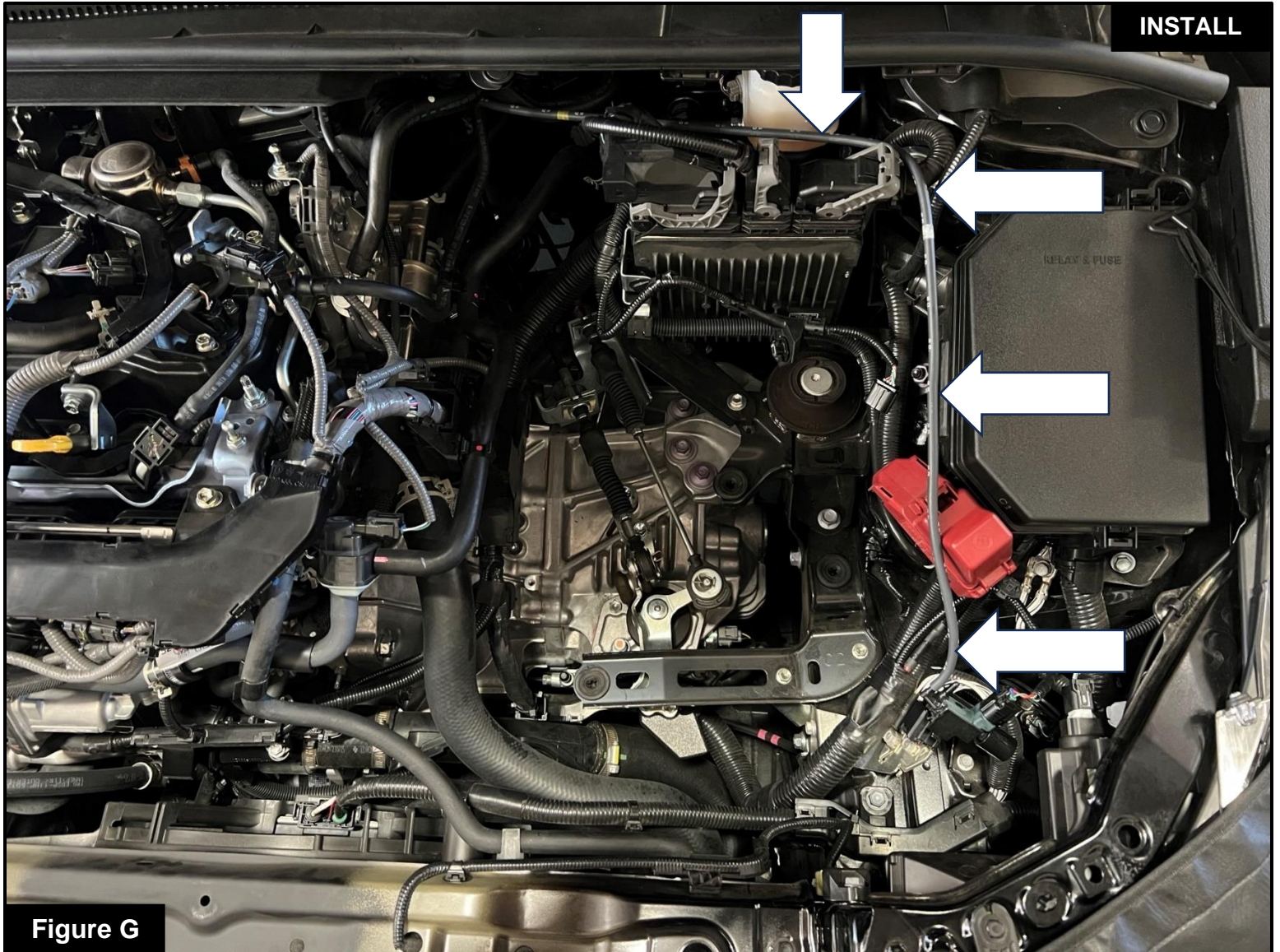

Refer to Figure G for Steps 13-14

Step 13: Remove intake tube and airbox as a unit.

Step 14: At this time, move the vacuum house off to the side as shown on figure G.



Figure H

Refer to Figure H for Step 15

Step 15: Remove the MAF sensor from factory airbox using a phillips screddriver.



Figure I

Refer to Figure I for Step 17

Step 17: Transfer the MAF sensor onto the Takeda tube and secure it using the provided T-20 Torx M4 screws.



Figure J

Refer to Figure J for Step 18

Step 18: Install the aluminum M6 fitting onto the Takeda hosing using an adjustable wrench.



Figure K

Refer to Figure K for Step 19

Step 19: Clip the two (2) vacuum hose holders onto the Takeda housing. Orient them as shown.

INSTALL



Figure L

Refer to Figure L for Step 20

Step 20: Install the cap on to the actuator.

**Figure M****Refer to Figure L for Step 21**

Step 21: Install Takeda housing. **NOTE:** Inspect that the aluminum fittings on the housing are fully seated into the factory grommets.



Refer to Figure N for Steps 22-23

Step 22: Install the actuator to the Takeda housing using the supplied screw.

Step 23: Secure the vacuum hose onto the clips on the housing.



Figure O

Refer to Figure O for Step 24

Step 24: Install coupling with hose clamp onto turbo inlet loosely, do not tighten clamps.



Figure P

Refer to Figure P for Step 25

Step 25: Install filter into the Takeda housing. Do not tighten clamp.

**Figure Q****Refer to Figure Q for Steps 26-29**

Step 26: Carefully install Takeda tube by sliding it into the coupling first and then into the filter. Make sure the tube lines up properly.

Step 27: Tighten all clamps.

Step 28: Attach hose to the Takeda Tube.

Step 29: Re-connect the MAF sensor.

**Figure R****Refer to Figure R for Step 30**

Step 30: Install factory scoop into Takeda housing and install the factory retainer clips as shown.

- If you have purchased a TAKEDA DAS for this intake system (56-70065S), please refer to the installation instructions provided with the TAKEDA DAS for its installation. You can Skip Steps 30-31 in this booklet

Figure S

Refer to Figure S for Steps 31-32

Step 31: Install the TAKEDA plug. The kit includes an optional plug to close off the auxiliary air inlet.

- **Without the plug installed, the TAKEDA intake will capture the maximum amount of air available. More airflow can lead to increased power, but some of this air may come from inside the engine compartment and could be warmer, potentially affecting vehicle performance.**
- **Installing the plug on the housing will block out hot engine air, ensuring that only the coolest air is directed into the engine. This will also help reduce intake noise**

Step 32: Install front cover and install the seven (7) factory retainer clips.



Your installation is now complete. Thank you for choosing Takeda USA!

NOTE: Check to ensure that all screws, clamps, and connectors are secure after 100-200 miles.



advanced FLOW engineering, inc.

Corona, CA 92879

<https://afepower.com/contact>